

# **STRENGTHENING TRADE CAPACITY – THE ROLE OF LABORATORY ACCREDITATION**

---

***GISELLE GUEVARA***

***MANAGER, LABORATORY ACCREDITATION SERVICE***

***TTLABS/TTBS***

***CROSQ SME CONFERENCE***

***18<sup>th</sup> July 2007***

***TRINIDAD AND TOBAGO***



# INTRODUCTION

---

Standards and technical regulations in developed countries affect a firms' propensity to export in developing countries.

In particular, **testing procedures** and lengthy inspection procedures by importers reduce exports by 9% and 3%, respectively.

The difference in standards across foreign countries causes diseconomy of scale for firms and affects decisions about whether to enter export markets.

Therefore, standards impede exporters' market entry, reducing the likelihood of exporting to more than three markets by 7%.



# International Trade – Present situation

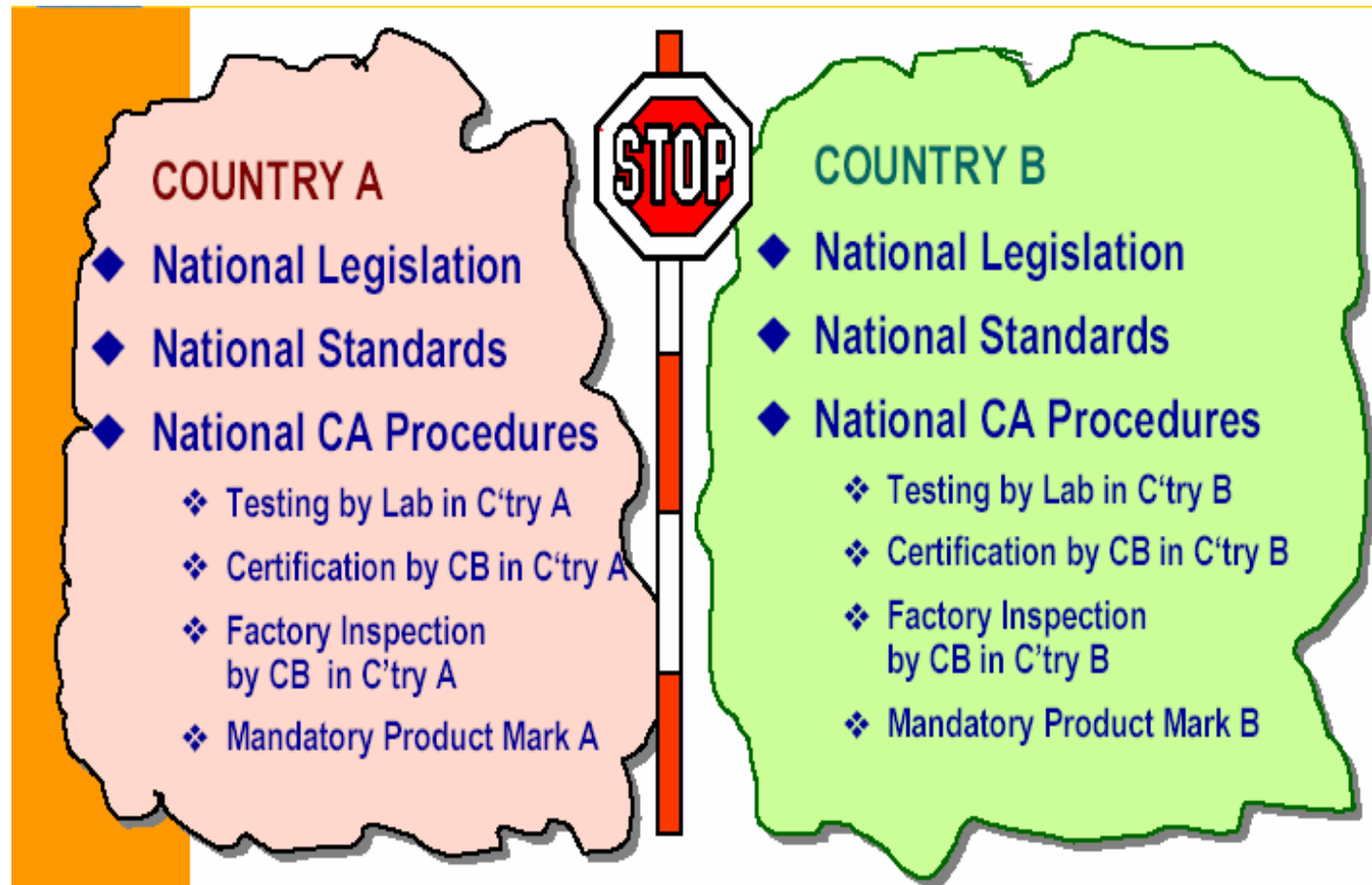

# Lower Barriers to Trade

---

- **Many countries have one or more organisations responsible for the accreditation of their nation's laboratories.**
- **This has helped countries employ a uniform approach to determining laboratory competence.**
- **It has also encouraged laboratories to adopt internationally accepted testing and measurement practices, where possible**
- **This uniform approach allows countries to establish agreements among themselves, based on mutual evaluation and acceptance of each other's laboratory accreditation systems.**
- **Such international agreements, called mutual recognition arrangements (MRAs), are crucial in enabling test data from accredited laboratories to be accepted between these countries.**
- **In effect, each partner in such an MRA recognises the results produced by the other partner's accredited laboratories, as if they themselves had undertaken the accreditation of the other partner's laboratories.**

# WTO AND TBT REQUIREMENTS

---

**Strong Conformity Assessment procedures, Strong Conformity Assessment Bodies**

**Accreditation of Conformity Assessment, Consistent procedures**

WTO/TBT Articles 5.5 and 9.1

*5.5 - With a view to harmonizing conformity assessment procedures on as wide a basis as possible, Members shall play a full part ... in the preparation by appropriate international standardizing bodies of guides and recommendations for conformity assessment procedures.*

*9.1 - Where a positive assurance of conformity with a technical regulation or standard is required, Members shall, where practicable, formulate and adopt international systems for conformity assessment and become members thereof or participate therein.*

## CSME

**Free trade of products**

**Equivalent services - Conformity Assessment**

**Tourism and Work force depend on reliable medical services**

# LABORATORY ACCREDITATION

---

Laboratory accreditation provides formal recognition to competent laboratories, providing a ready means for customers to identify and select reliable testing, measurement and calibration services.

To maintain this recognition, laboratories are re-evaluated regularly by the accreditation body to:

- ensure their continued compliance with requirements; and
- check that their standard of operation is being maintained.

The laboratory is also required to participate in relevant proficiency testing programs between reassessments, as a further demonstration of technical competence.



---

# Who cares about Testing?





# The World?

---

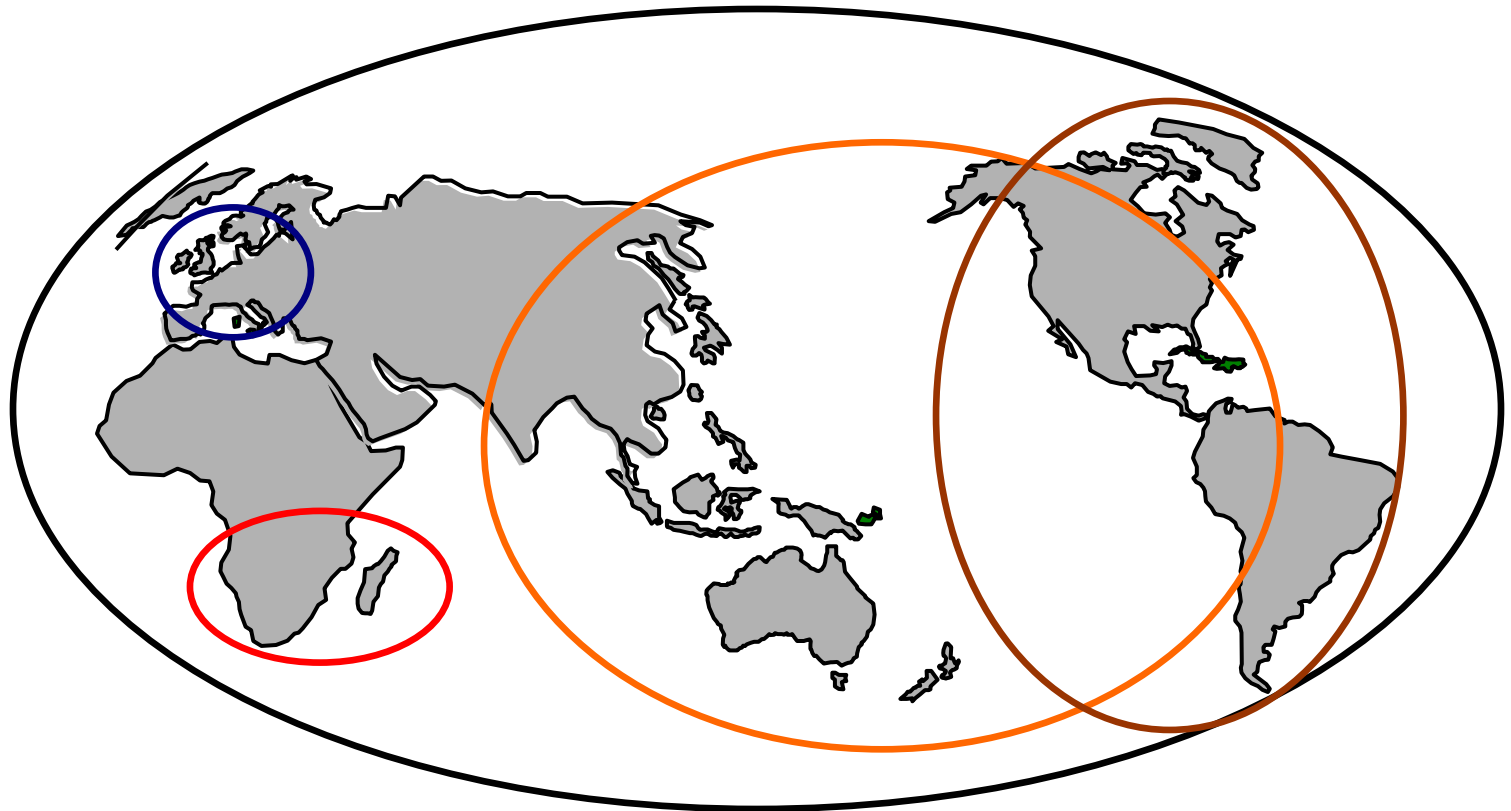

# Government/Regulatory Responsibility: The Importance of Decision-Making

---

**Government bodies and regulators are constantly called upon to make decisions related to:**

- Protecting the health and welfare of consumers and the public;
  - Protecting the environment;
  - Developing new regulations and requirements;
  - Assessing compliance;
  - Allocating resources.
- **Government bodies and regulators must have confidence in data generated by laboratories to make these decisions.**
- Using an accredited laboratory can help establish and assure this confidence.



## Value-added chain



Applicable to all products and processes.

## National quality infrastructure

## International QI system

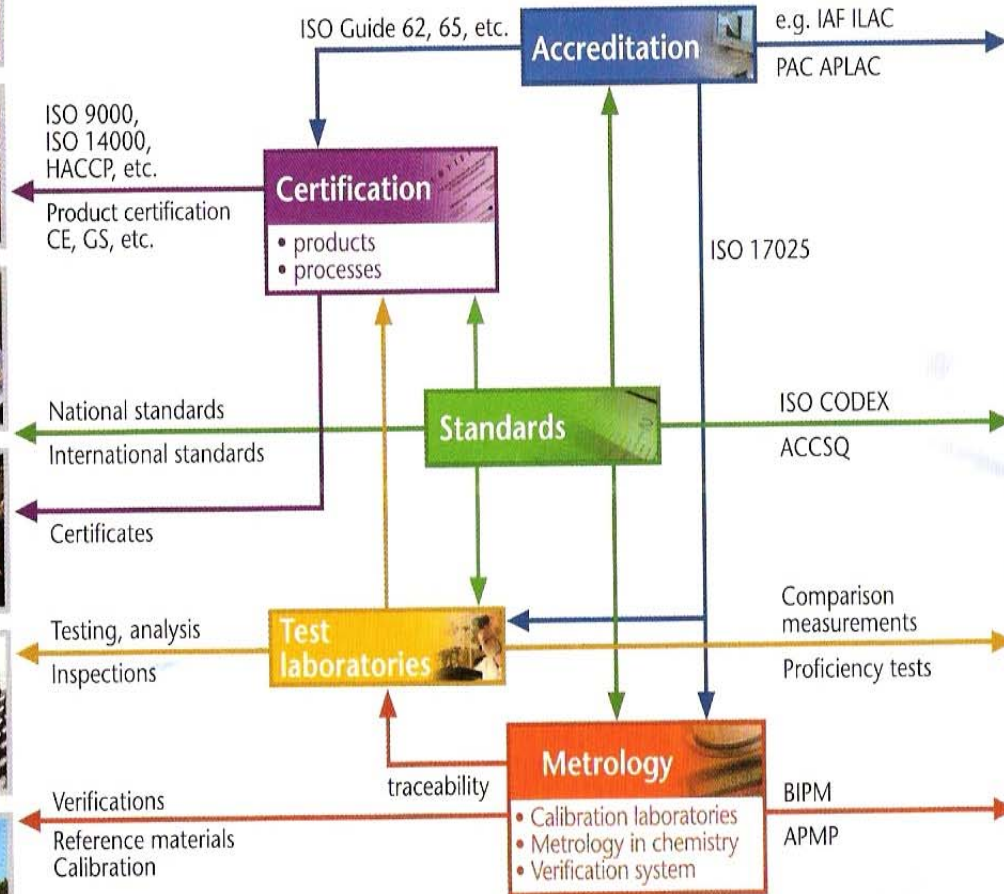
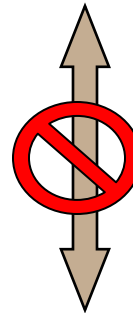

Diagram: Survey of the national quality infrastructure

# Accreditation vs Certification

---

**Accreditation to ISO/IEC 17025 or ISO 15189**, the emphasis is to establish the technical competence for a defined set of tests, measurements or calibrations. Laboratory accreditation uses criteria and procedures specifically developed to **determine technical competence**



**Certification to ISO 9001** establishes compliance

Of the quality management system to the standard, it does not contain technical requirements for lab personnel & operations

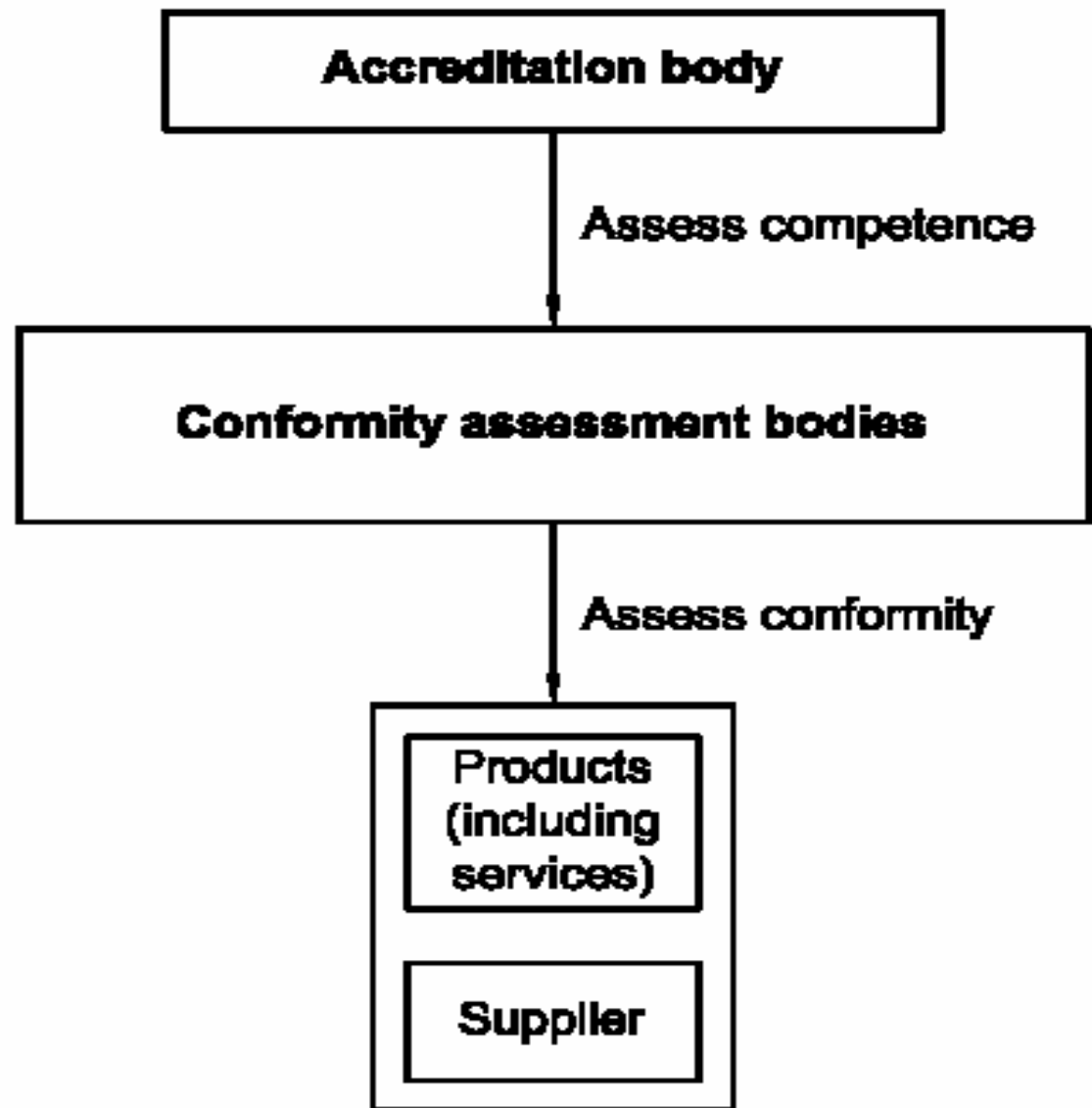

# Why is Technical Competence so critical?

**Minimise Risks of  
Faulty Products**

**Reduce costs &  
improve acceptance  
of products**

**Enhance  
Trade**

**Avoid Expensive  
retesting**

**Enhance  
customer  
confidence**

# Why is a Lab's Technical Competence so Critical to You?

---

## Minimise Risk

- **Throughout the world today, customers seek reassurance that the products, materials or services they produce or purchase meet their expectations or conform to specific requirements.**
- **This often means that the product is sent to a laboratory to determine its characteristics against a standard or a specification.**
- **For the manufacturer or supplier, choosing a technically competent laboratory minimises the risk of producing or supplying a faulty product.**



# Why is a Lab's Technical Competence so Critical to You? (cont'd)

---

## Avoid Expensive Retesting

- **Testing of products and materials can be expensive and time consuming, even when they are done correctly the first time.**
- **If not done correctly, then the cost and time involved in retesting can be even higher if the product has failed to meet specifications or expectations.**
- **Not only costs go up, but your reputation as a supplier or manufacturer can go down.**
- **You can also be held liable for any failure of your product, particularly if it involves public safety or financial loss to a client.**
- **Choosing a technically competent laboratory minimises the chance of retesting being required.**



# Why is a Lab's Technical Competence so Critical to You? (cont'd)

---

## Enhance Your Customers' Confidence

- Confidence in your product is enhanced **if clients know it has been thoroughly evaluated by an independent, competent testing facility.**
- **This is particularly so if you can demonstrate to them that the laboratory itself has been evaluated by a third party.**
- **Increasingly customers are relying on independent evidence, rather than simply accepting a supplier's word that the product is "fit for purpose".**



# Why is a Lab's Technical Competence so Critical to You? (cont'd)

---

## Reduce Costs and Improve Acceptance of Goods Overseas

- **Through a system of international agreements technically competent, accredited laboratories receive a form of international recognition.**
- **This recognition allows their data to be more readily accepted on overseas markets.**
- **This recognition helps to reduce costs for manufacturers and exporters that have their products or materials tested in accredited laboratories, by reducing or eliminating the need for retesting in the importing country.**



# How Can You Tell if a Laboratory is Accredited?

---

**Accredited laboratories usually issue test or calibration reports bearing the accreditation body's symbol or endorsement, as an indication of their accreditation.**

- **Clients are encouraged to check with the laboratory as to what specific tests or measurements they are accredited for, and for what ranges or uncertainties.**
- **This information is usually specified in the laboratory's scope of accreditation, issued by the accreditation body.**
- **The description in the scope of accreditation also helps customers find the appropriate laboratory for their specific testing needs.**
- **Accreditation bodies publish scopes of accreditation in hardcopy directories or on the internet.**



# The Quality Chain

---

**Qualified  
Staff**

**Correct  
Equipment**

**Quality  
Assurance**

**Proper  
Sampling**

**Good Test  
Methods**

# Secondary Quality Chain

---

**Accurate Reporting**

**Suitable Facilities**

**Traceability of Measurements**

**Qualified Personnel   Proper Quality Sampling   Good Test**

**Monitoring and Evaluation**

**Equipment   Methods**

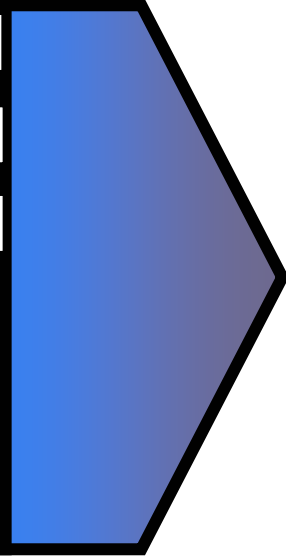

# Important Factors When Selecting a Laboratory

---

•A laboratory must be able to supply you with accurate and reliable testing, calibration or measurement results.

•Factors contributing to the technical competence of a laboratory include:

- Qualifications, training and experience of the staff;
- Correct equipment – properly calibrated and maintained;
- Adequate quality assurance procedures;
- Proper sampling practices;
- Appropriate and valid testing procedures and methods;
- Traceability of measurement to national standards;
- Accurate recording and reporting procedures;
- Suitable testing facilities.



# LABORATORY ACCREDITATION ENCOURAGES GROWTH

---

Using accredited laboratories also facilitates trade and economic growth. Here's how:

- The accrediting process relies on a **uniform approach** to determining laboratory competence.
- This uniform approach has been accepted and implemented **across many borders**.
- Data generated by an accredited laboratory may lead to **ready acceptance of exported goods** in overseas markets.
- This **reduces costs and eases exports and imports**, as it reduces or eliminates the need to retest in another country.



---

# REGIONAL LABS



# **CHALLENGES - Infrastructure Deficits**

---

- **Temperature controls (Air conditioning units, etc)**
- **Rest room facilities**
- **Waste disposal**
- **Facilities for production of reagent grade water**
- **Appropriate sterilization and cleaning facilities**
- **Appropriate decontamination areas**
- **Adequate electrical supply and placement of outlets**
- **Safety**



# **CHALLENGES**

## **- Quality Assurance/Quality Control (QA/QC)**

---

- Requirement for a change in culture in organization**
- Procedures not consistently followed by staff**
- Inadequate documentation**
- Lack of Dedicated Quality Manager - To ensure implementation of the quality management system (QMS)**
- Difficulty getting persons to produce documentation**

## **Human Resources**

- Inadequate numbers**
- Lack of adequate competence**
- Staff resistance to change**
- Procurement problems**
- Inventory Management – inadequate**
- Ancillary support i.e., non-technical**



# Statistics – MEDICAL LABS SURVEYED

---

## QUALITY MANAGEMENT

25% of labs have staff assigned to quality

17% of labs have a quality manual

21% have staff-conducted quality assessments

vs

75% of labs do NOT have staff assigned to quality

>66% do NOT have a quality manual

>50% do not have internal assessments

## QUALITY CONTROL

42% labs have a QC policy

29% statistically evaluate new tests

58% always have QC material

vs

>50% do NOT have a QC policy

>46% do NOT evaluate new tests

>17% may sometimes NOT have QC material

# Statistics - Sample Handling

---

**92% of labs have a specific sample collection area**

**63% assign unique ID numbers to all samples**

**vs**

**>33% of labs do not assign unique IDs**

**>71 % of labs do NOT have a policy for implementing a new test**

## Data Management

**17% labs have an information policy**

**42% have an information management system**

**vs**

**>79% labs have NO information policy**

**>42% labs do NOT have an information management system**



# STATISTICS - SAFETY

---

67% do NOT have a safety policy

92% do NOT have a safety programme

71% do NOT have a safety officer

88% do NOT have a written waste disposal procedure

vs

63% do autoclave all infectious waste

83% have fire extinguishers but only 8% have fire drills



# MEDIOCRITY

IT TAKES A LOT LESS TIME  
AND MOST PEOPLE WON'T NOTICE THE DIFFERENCE  
UNTIL IT'S TOO LATE.

---

# REGIONAL ACCREDITATION SYSTEM



# GLOBALIZATION

---

- The Growth in International trade causes an increase in technical requirements for trade stipulated by buyers
- Lack of capacity and cooperation hurts SMEs in several ways:
  - Inadequate local testing and calibration services
  - Limited access to information on export requirements (Export Alert)
  - Expensive processes for traded product approval
  - Excessive bureaucracy and prolonged delays in product movements
  - Closed or lost market opportunities



# BASIC CHALLENGES

---

Where accreditation bodies have been established there are many challenges:

- Lack of understanding among the regulators of the role accreditation plays in eliminating technical barriers to trade and increasing exports & imports.
- Many authorities do not know the difference between certification & accreditation (Only accreditation can be offered by a third party, Certification may be granted by first, second and/or third party bodies)
- Most developing countries have scarce resources to achieve optimum results for accreditation
- **Solution**

Where conformity assessment bodies (CABs) cannot support the country's accreditation service; develop a joint service (either regionally or in a trade block)

# ACCREDITATION IN ACTION

## *Bottled Drinking Water into an Asian Country*

The conclusion of the Uruguay Round opened many markets to products that had previously been banned. One such product is bottled drinking water. Drinking water is, however, required to be tested for chemical characteristics and microbiological content. The authorities may also require historical tests of the water at source and following processing. A major New Zealand exporter was able to have his fresh, clean water from New Zealand accepted in a new market in Asia because his test reports came from an IANZ-accredited laboratory. The Asian regulator accepted the New Zealand test reports because IANZ is a signatory of the ILAC Arrangement.

# REGIONAL INTEGRATION

---

- **Allow smaller Economies to access Accreditation Services cost effectively**
- **Promote harmonisation of Conformity Assessment procedures**
- **Ensure traceability of measurements**
- **Ensure accurate data production and reporting**
- **Raise level of service by labs in the region**
- **Increase Expertise in the Region**



# Benefits of Regional System

---

Pool of Assessors and Experts

Shared costs of Proficiency Testing

Traceability of Measurements

Development of Human Resources

Encourage Training within the Region

Technical Cooperation among countries

Decrease overall cost of Accreditation

Strong Regional Infrastructure

**National Accreditation focal points provide:**

- **Training**
- **Access to Proficiency Testing programs**
- **Sensitization workshops, seminars, meetings**
- **Printed materials, presentations**



<b>white</b>	Work not yet started
<b>yellow</b>	Work in progress
<b>green</b>	Work nearly finished

I x - Implementation	67%
S x - Sustainability	17%
V x - Velocity (p.a.)	9%
Mean Value	51%

CLAS 01 2007			
Mile-stone	Percent-age	Mile-stone	Percent-age
MS 01	80%	MS 16	70%
MS 02	80%	MS 17	70%
MS 03	50%	MS 18	70%
MS 04	50%	MS 19	20%
MS 05	40%	MS 20	50%
MS 06	30%	MS 21	50%
MS 07	60%	MS 22	20%
MS 08	30%	MS 23	50%
MS 09	30%	MS 24	50%
MS 10	30%	MS 25	50%
MS 11	100%	MS 26	50%
MS 12	30%	MS 27	50%
MS 13	80%	MS 28	30%
MS 14	20%	MS 29	90%
MS 15	70%	MS 30	30%

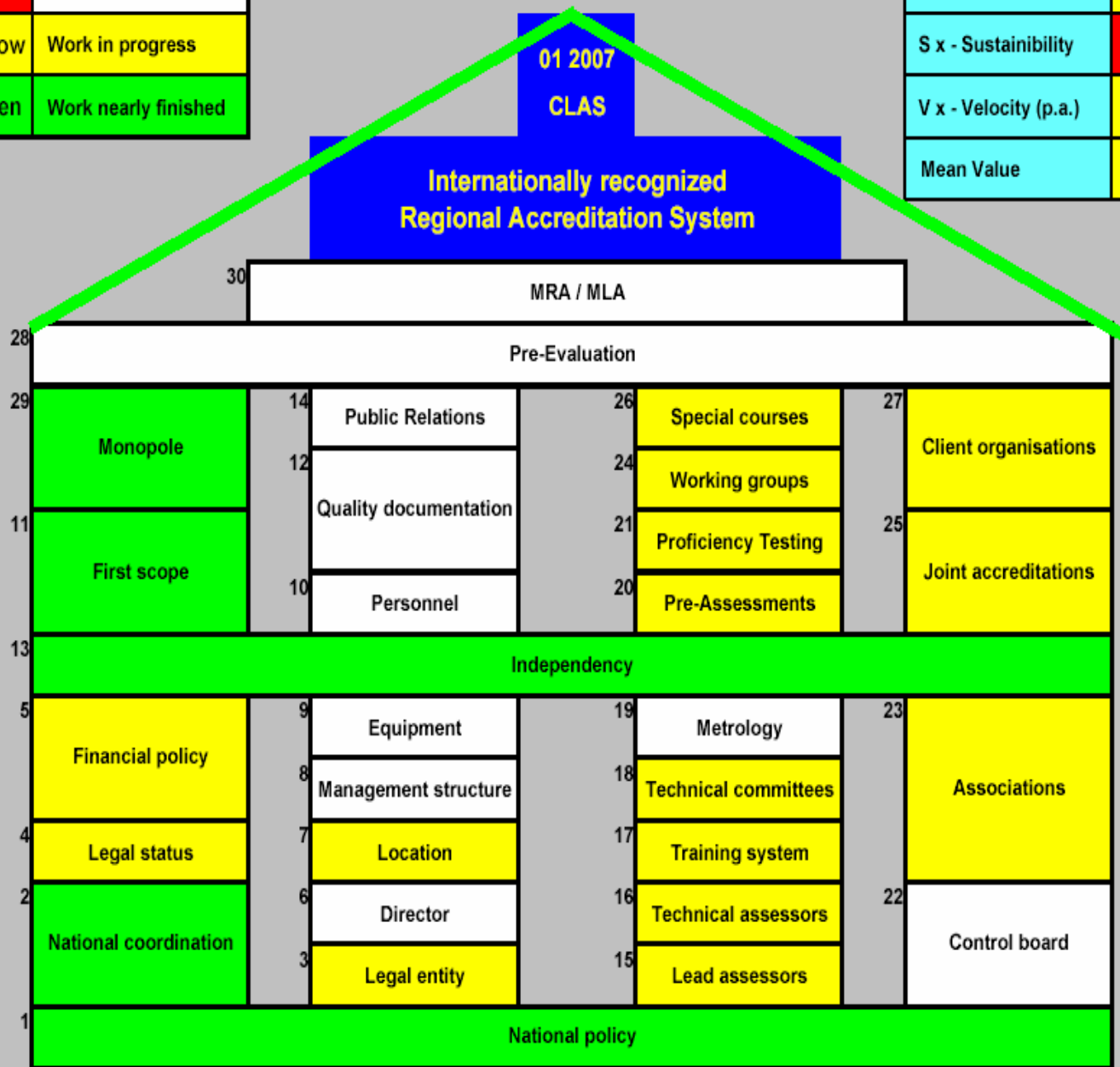

# A Benchmark for Performance

---

**Accreditation benefits conformity assessment bodies by:**

- allowing them to determine whether they are performing their work **correctly and to appropriate standards**; and
- providing them with a recognised **benchmark** for maintaining that competence.

**Many conformity assessment bodies** operate in isolation, and rarely, **receive any independent technical evaluation in order to objectively** measure their performance.

**Manufacturing organizations** may use **accreditation** to **ensure** the testing of their products by their own in-house laboratories is being **done correctly**.



# The Next Step for Government: A Worldwide Advantage

---

**Many countries have entered into mutual recognition arrangements (MRA's), created to allow mutual acceptance of each other's laboratory accreditation systems (e.g. ILAC MRA)**

**Such international agreements enable test data to be accepted between these countries.**

**In effect, each MRA partner recognises the other partner's accredited laboratories as if they themselves had accredited the other partner's laboratories.**

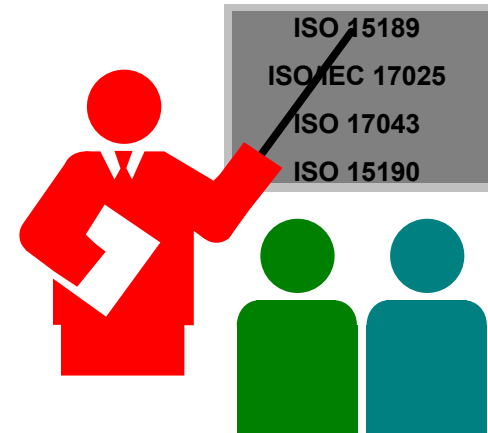

# WHEN IS THE RIGHT TIME?

---

- Does the Region wait until we are developed?
- Do we wait for a crisis, e.g. Disease outbreaks?
- Do we wait for someone else to enable the process?
- Do we wait for Overseas companies to establish entities and charge high fees?
- Do we make it happen ourselves?



# Accreditation, a tool to support processes leading to competence

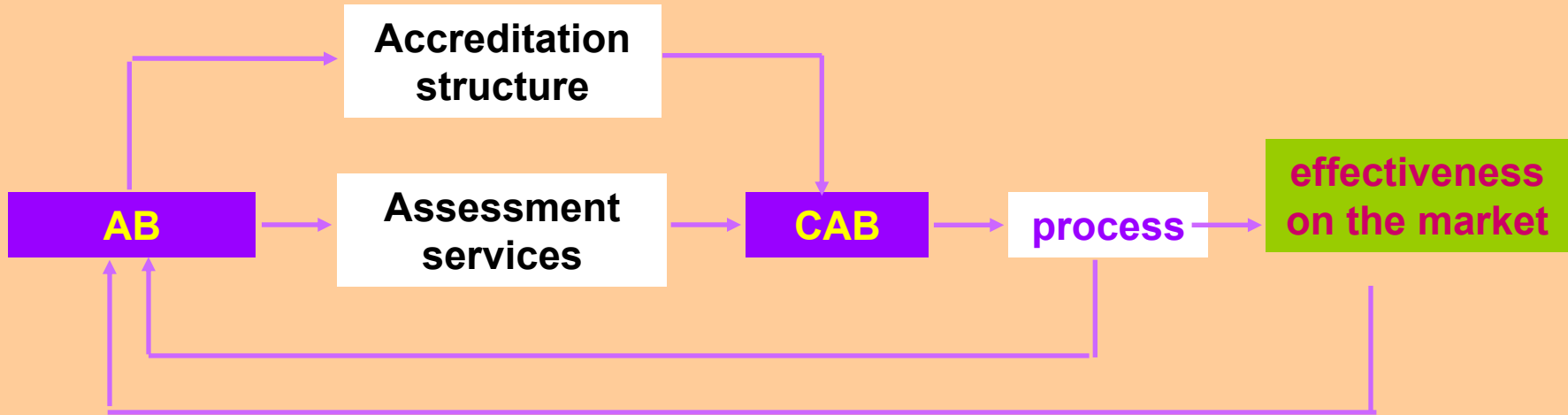

- Accreditation should be seen as a structure to ensure, maintain and continuously improve competence of CAB's.
- AB's observe this process, and whether a benefit is resulting
- AB's give input and feedback to the assessed organisation

## **CONCLUSION**

---

**This region is faced with many challenges on its path to development**

**With continued growth, hard work, and encouragement, the Caribbean can overcome any hurdle**

**Businesses can prosper - Nations can grow**

**Harmonisation of Accreditation criteria ensures that results are widely accepted, Trade is not hindered and high quality lab services are the norm**



# GET TO WORK

YOU AREN'T BEING PAID TO BELIEVE IN THE POWER OF YOUR DREAMS.

[www.despair.com](http://www.despair.com)

August 2007

# Laboratory Accreditation

*TESTED ONCE, ACCEPTED  
EVERYWHERE*

- [giselle.guevara@ttbs.org.tt](mailto:giselle.guevara@ttbs.org.tt)

*RIGHT THE FIRST TIME*